

2018 年度日本政府（文部科学省）奨学金留学生選考試験
QUALIFYING EXAMINATION FOR APPLICANTS FOR JAPANESE
GOVERNMENT (MEXT) SCHOLARSHIP 2018

学科試験問題
EXAMINATION QUESTIONS

高等専門学校留学生
COLLEGE OF TECHNOLOGY STUDENTS

物理
PHYSICS

注意 ☆試験時間は 60 分

PLEASE NOTE: THE TEST PERIOD IS 60 MINUTES

(2018)

PHYSICS

Nationality		No.	
Name	(Please print full name, underlining family name.)		

Marks	
-------	--

1. An object with a mass of 4.0 kg being suspended by a massless string is at rest on a rough plane inclined at an angle of 30° , as shown in the figure below. The string is kept to be parallel to the inclined plane. Answer the following three questions, using the coefficient of static friction 0.20, the gravitational acceleration 9.8 m/s^2 and $\sqrt{3} = 1.73$. Give your answers under two significant figures, after calculating under three significant figures.

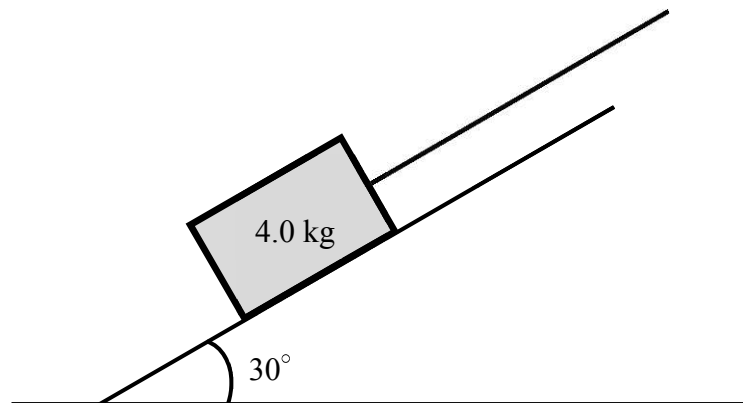

- (1) Find the maximal friction force between the object and the inclined plane.

(1)	N
-----	---

- (2) Find the minimal force to pull up the object along the inclined plane.

(2) N

- (3) Let the object be at rest again. Then, after cutting the string, the object starts to slide down the slope due to gravity. Find the acceleration of the object during its subsequent motion. Use the coefficient of kinetic friction 0.050.

(3) m/s^2

2. Object B is moving at a speed of 6.0 m/s on a smooth horizontal plane towards object A at rest, as shown in the left figure below. After the collision, as shown in the right figure, objects A and B are scattered in directions at an angle of 60° and 30° , respectively. Find the speeds v_A and v_B of objects A and B, respectively, where each object has an identical mass and never rotates. Use $\sqrt{3} = 1.73$. Give your answers under two significant figures, after calculating under three significant figures.

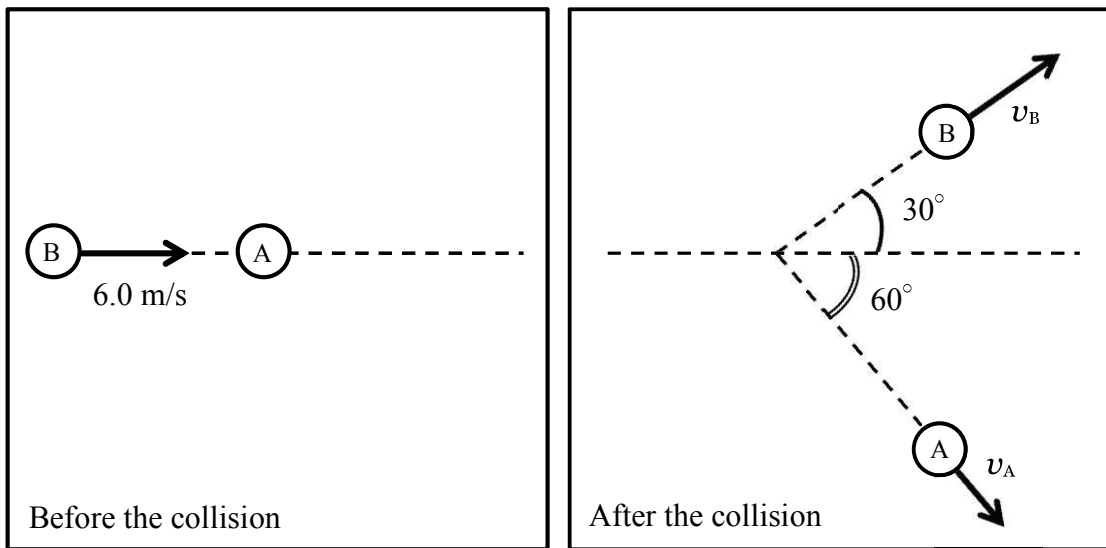

v_A	m/s
-------	-----

v_B	m/s
-------	-----

3. Consider a system with two boxes A and B connected by a sufficiently small tube with a stopcock. Initially the stopcock is closed. As shown in the figure below, in the initial state, a volume, an absolute temperature, and a pressure of an ideal gas in box A are 0.020 m^3 , 285 K , and $1.2 \times 10^5 \text{ Pa}$, and those of an ideal gas in box B are 0.040 m^3 , 385 K , and $1.6 \times 10^5 \text{ Pa}$, respectively. Answer the following four questions, using the gas constant $8.31 \text{ J}/(\text{mol}\cdot\text{K})$. Give your answers under two significant figures, after calculating under three significant figures.

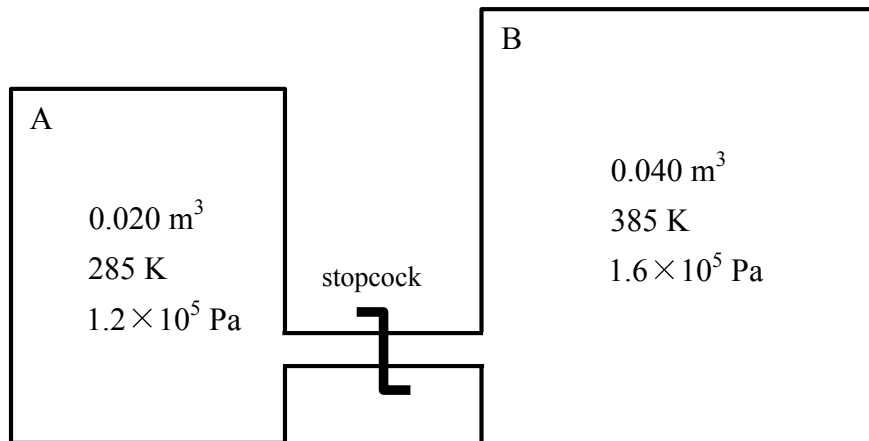

- (1) Find the number of moles n_A for the ideal gas in box A.

(1) mol

- (2) Find the number of moles n_B for the ideal gas in box B.

(2) **mol**

- (3) Find the absolute temperature T of the ideal gas, after the stopcock is opened and the system is in thermal equilibrium.

(3) **K**

- (4) Find the pressure P of the ideal gas, after the stopcock is opened and the system is in thermal equilibrium.

(4)

Pa

4. Answer the following three questions on the Doppler effect for sound. The sound source and the observer move in the same straight line. Assume that the speed of sound is 340 m/s. Give your answers under two significant figures, after calculating under three significant figures.

(1) The observer at a speed of 30 m/s is approaching the stationary sound source that has a frequency of 100 Hz. Find the frequency heard by the observer.

(1)	Hz
-----	----

(2) The sound source, at a speed of 30 m/s, that has a frequency of 100 Hz is approaching the stationary observer. Find the wavelength observed by the observer.

(2)	m
-----	---

(3) The sound source that has a frequency of 100 Hz is moving at a speed of 30 m/s, and the observer is moving at a speed of 40 m/s in the same direction (*i.e.* the source is chasing the observer from behind). Find the frequency heard by the observer.

(3)	Hz
-----	----

5. Answer the following three questions. Give your answers under two significant figures, after calculating under three significant figures.

(1) Find the total resistance of four resistors connected as shown below.

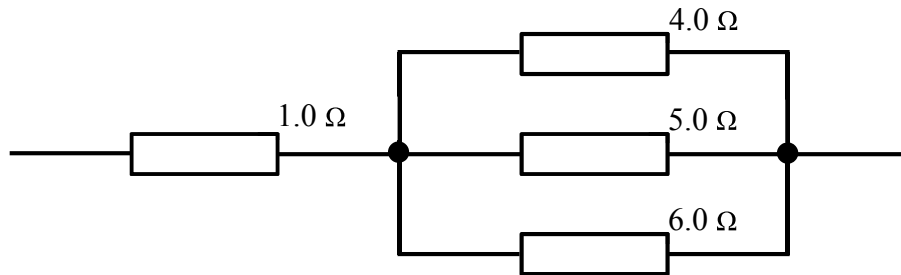

(1)	Ω
-----	----------

(2) Find the total capacitance of four capacitors connected as shown below.

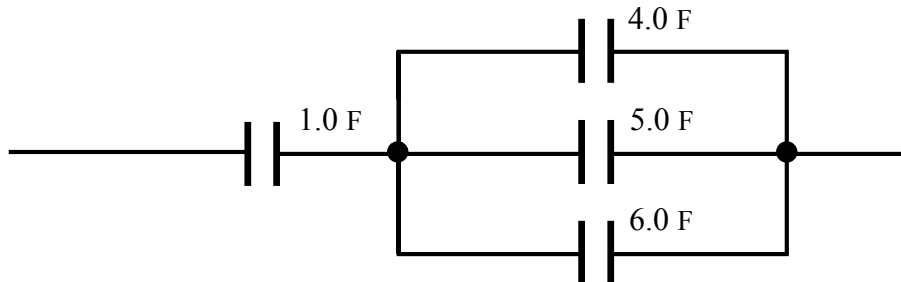

(2)	F
-----	----------

- (3) In the circuit with four resistors and a galvanometer G as shown below, R is an unknown resistance. Find the resistance R to keep the galvanometer to be 0 A .

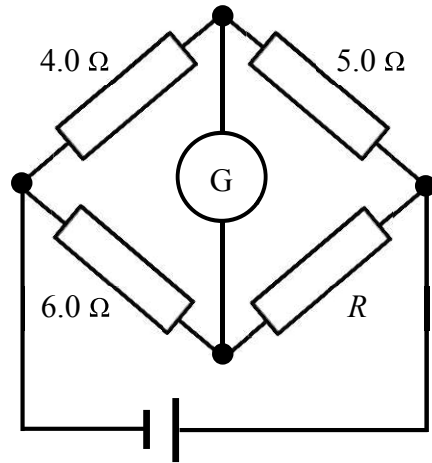

(3)

Ω

6. Answer the following two questions. Use 3.14 as the ratio of the circumference of a circle to its diameter ($\pi = 3.14$), and $\sqrt{3} = 1.73$. Give your answers under two significant figures, after calculating under three significant figures.

(1) Two infinitely long straight wires are placed in parallel, 4.0 m apart from each other as shown in the figure below. Each wire carries a current of 4.5 A in the same direction. Find the magnitude of the magnetic field at point P, 4.0 m apart from each wire.

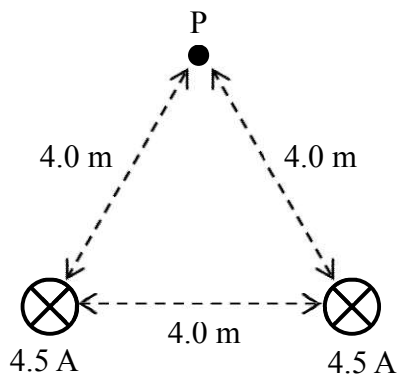

(1)	A/m
-----	-----

(2) An infinitely long straight wire and a circular loop of wire of a radius of 1.0 m are placed on a plane as shown in the figure below. The center (point Q) of the circle is 3.0 m apart from the straight wire. Find the magnitude of the magnetic field at point Q when each wire carries a current of 5.0 A in the directions indicated by the arrows.

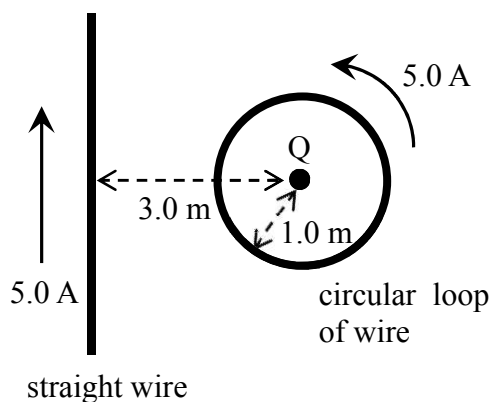

(2)	A/m
-----	-----

7. Answer the following three questions. Use the gravitational acceleration g , the electrostatic constant of Coulomb's law k , and the gas constant R . It is unnecessary to calculate numerical values of fractions and square roots.

(1) An object with a mass of m is thrown downward with an initial speed v_0 from the point of a height h at time $t = 0$. It reaches the ground at time t_∞ . Derive the position (height) of the object measured from the ground at time t ($0 < t < t_\infty$).

(1)

(2) Three point charges q are placed at the corners of a square with a length of a side of a as shown in the figure below. Derive the magnitude of the electric field at corner A.

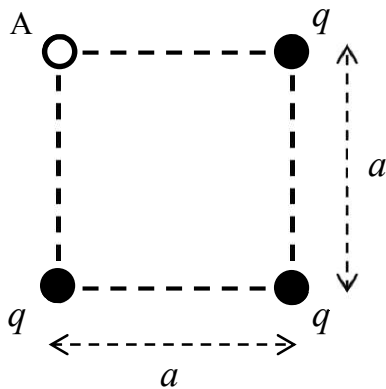

(2)

- (3) Consider a system of an ideal gas of 1.0 mole monoatomic molecules in a piston-cylinder arrangement. An external force F pushes the piston with a distance x , with giving a heat Q (*i.e.* the ideal gas is compressed and heated). Derive the temperature change (rise) of the ideal gas.

(3)